



Introducing the : MHM 4000 Static Compactor

www.mhmukltd.com

General Description

The MHM4000 Static Compactor is for high volume waste.

It is manufactured with an extra large charge box to take bigger items of industrial waste and it can handle civic amenity waste and is ideal for local authority sites.

Varieties of loading hoppers can be supplied including chute, conveyor and fork truck loading or by hydraulic bin lifter + safety cage

Key Features

- High compaction ratio
- Reduced fire risk
- Reduces vermin threat
- Total waste containment
- Reduced odour
- Reduces collection costs
- Prevents windblown trash
- Prevents unauthorised access to waste
- Improved on-site hygiene
- Automated pinning off for ease of use
- Full 12 months on-site parts and labour warranty

Technical Specification

Width:	2050mm
Length:	6200mm
Weight:	4500kg
Electric Motor:	11kw
Aperture Length:	2500mm
Aperture Width:	1550mm
Ram Depth:	917mm
Compaction Force:	32 T



MHM UK LTD

Unit C, Royalty Lane, Swineshead, Boston, Lincolnshire, PE20 3PJ

Tel : +44 (0)1205 821522

Email: sales@mhmukltd.com

Photographs for illustration purposes only

CE
Marked

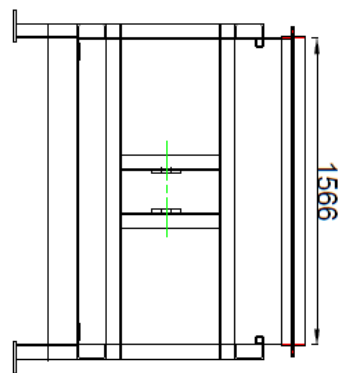
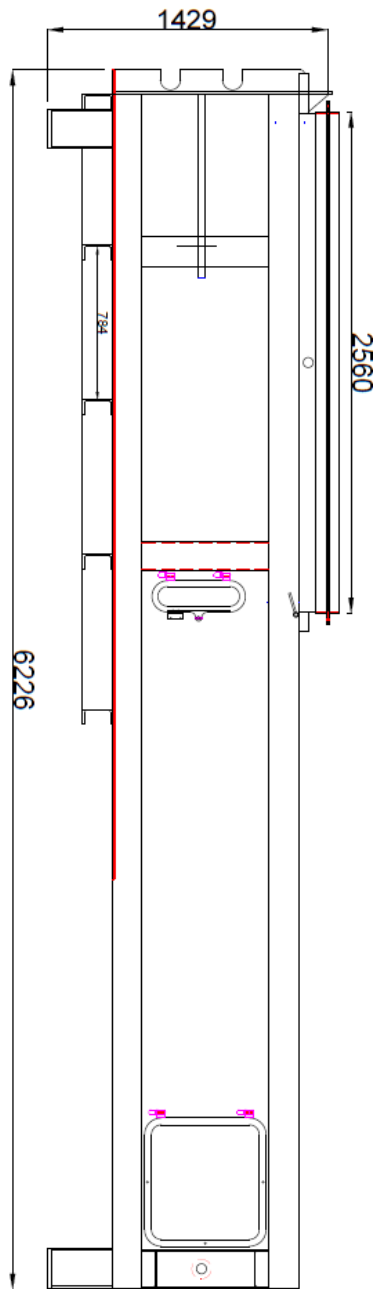
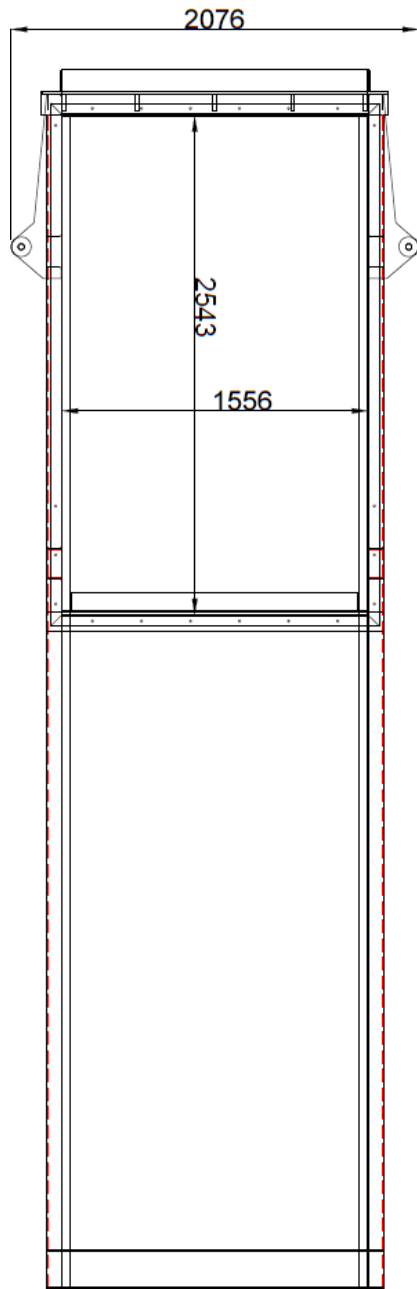

MHM UK LTD
Unit C, Royalty Lane, Swineshead, Boston, Lincolnshire, PE20 3PJ
Tel : +44 (0)1205 821522
Email: sales@mhmukltd.com

Photographs for illustration purposes only

