

**Introducing the:**  
**MHM BALER 500HD** producing tyre weight bales up to  
 610kg [www.mhmrecycling.com](http://www.mhmrecycling.com)



[www.mhmukltd.com](http://www.mhmukltd.com)

**General Description**

The Baler 500HD heavy duty baler has extra long rams to produce far denser bales than any standard baler. The entire frame-work of this model is reinforced and it has been fitted with our unique bale retaining system, allowing it to handle harder to bale materials such as car tyres, car bumpers, PET bottles, textiles and heavy duty materials.

12 months parts and labour warranty. CE marked and approved.

**Technical Specification**

Height: 3.570m  
 Width: 2.115m  
 Depth: 1.200m  
 Weight: 1930kg  
 Power Supply: 380 - 400 volt 11kw  
 32 amp 3 phase  
 Cycle time: 50 seconds

Noise: 75 d(B)A  
 Transport Height: 2.550m Bale  
 Dimensions  
 Height of Bale 1.200m Width of Bale  
 1.500m Depth of Bale 0.769m  
 Weight of Bale up to 610kg  
 (dependent on waste stream)  
 Loading aperture size  
 Height 0.880m  
 Depth 0.769m  
 Width 1.5m



Photographs for illustration purposes only

MHM UK LTD  
 Unit C Royalty Ln, Swineshead, Boston PE20 3PJ  
 Tel : +44 (0)1205 821522 Fax: +44 (0)1205 821554 Email: [sales@mhmukltd.com](mailto:sales@mhmukltd.com)



A: 3.570m  
B: 2.115m  
C: 2.266m  
D: 2.784m E: 2.500m F: 0.961m  
G: 0.881m  
H: 1.484m



[www.mhmukltd.com](http://www.mhmukltd.com)

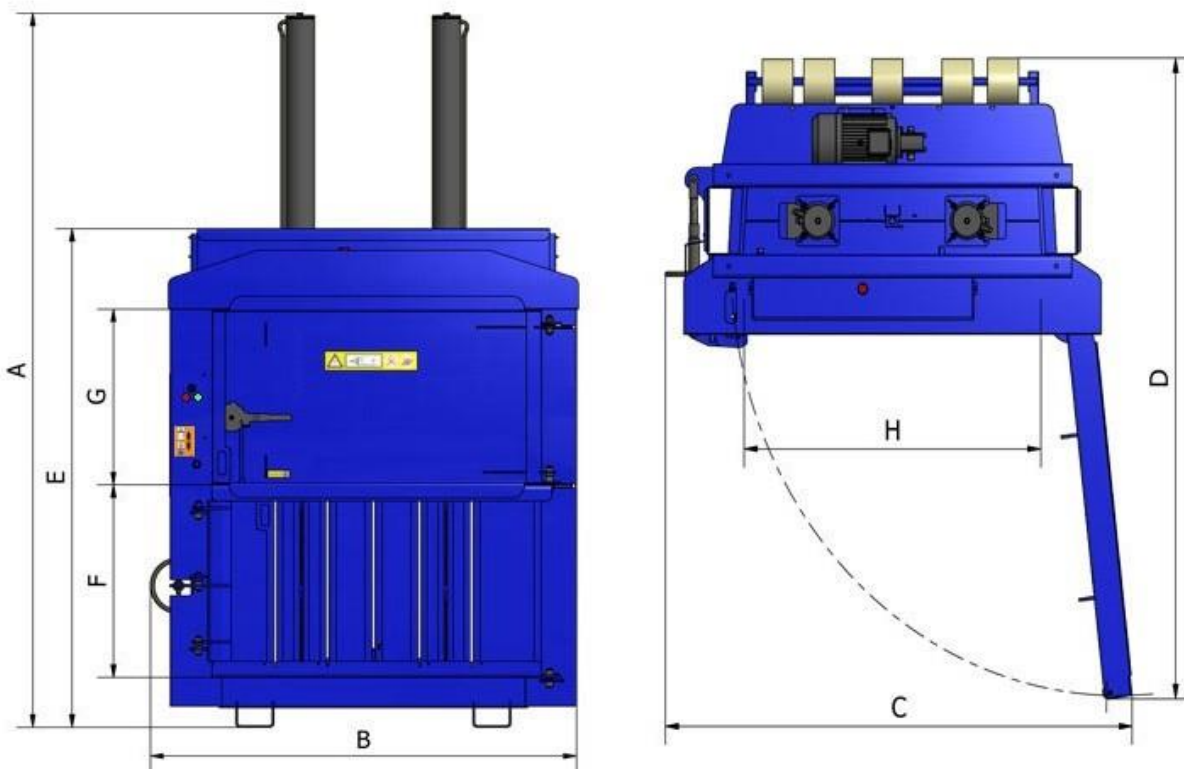

Photographs for illustration purposes only

---

MHM (UK) LTD  
Fenhouses Drove, Swineshead, Boston, Lincolnshire, PE20 3HE  
Tel : +44 (0)1205 821522 Fax: +44 (0)1205 821554 Email: sales@mhmukltd.com

